

3R Waste Management Concept

Unpad implements waste management with the 3R concept which refers to the Republic of Indonesia, Minister of Health Regulation No. 3 Year 2014 concerning community based total sanitation; reduce, reuse and recycle.

Based on data from the Administration sector, the volume of waste produced from Jatinangor and Dipati Ukur campuses is around 1 ton. It is estimated that the total waste which must be processed by Unpad is around 30 tons. It consists of organic and inorganic waste such as paper, styrofoams, glass and plastics. About 30 tons of waste from Dipatiukur is transported to Jatinangor every week. Organic waste such as leaves can become compost materials, but inorganic waste such as plastic has not been resolved. Unpad waste treatment is optimized as much as possible to separate inorganic and organic waste, so the compost production can be effective. However, there is still an issue as part of total waste is still not well-separated (i.e plastic, glass, rubber, and styrofoam). This issue is currently handled by manual incinerator on landfill site. The incinerator capacity is around 6 tons per operation (once a week). However, medical waste management is handled by a government-certified third party, namely PT. Jasa Medinvest.

Sorting

Waste sorting at Unpad has now been carried out and is a simple first step of the 3R activity. Generally, sorting can be done based on the type of waste; organic and inorganic. Organic waste includes food scraps from canteens and stalls, vegetables and other perishable waste. Inorganic waste generally consists of plastics, glass bottles, and cans.

These activities, especially plastic waste sorting, provide benefits for resales and the sorting processes are relatively odorless. The volume of generated plastic waste and styrofoam paper materials in Unpad contributed > 40% of the total waste from the ideal volume ($\pm 20\%$). The potentials for reusing plastic waste needs to be increased through plastic waste sorting activities in the campus area. The main key for the success of this operation is the waste disposal accuracy based on the existing containers. Accuracy is needed as any factor which speeds up sorting activities will save time and costs. If it is done correctly, nearly 80% of all Unpad academic communities have carried out the sorting processes, starting from students, lecturers, education staffs to K3L officers. The current obstacles occur in K3L officers. Due to the lack of transport to the TPA, the waste is put back together after packaging as the cleaning staffs assume that the transportation will be easier.

Waste Management Calculation

Calculation is based on input from several sources per day and how it is processed as its follows below:

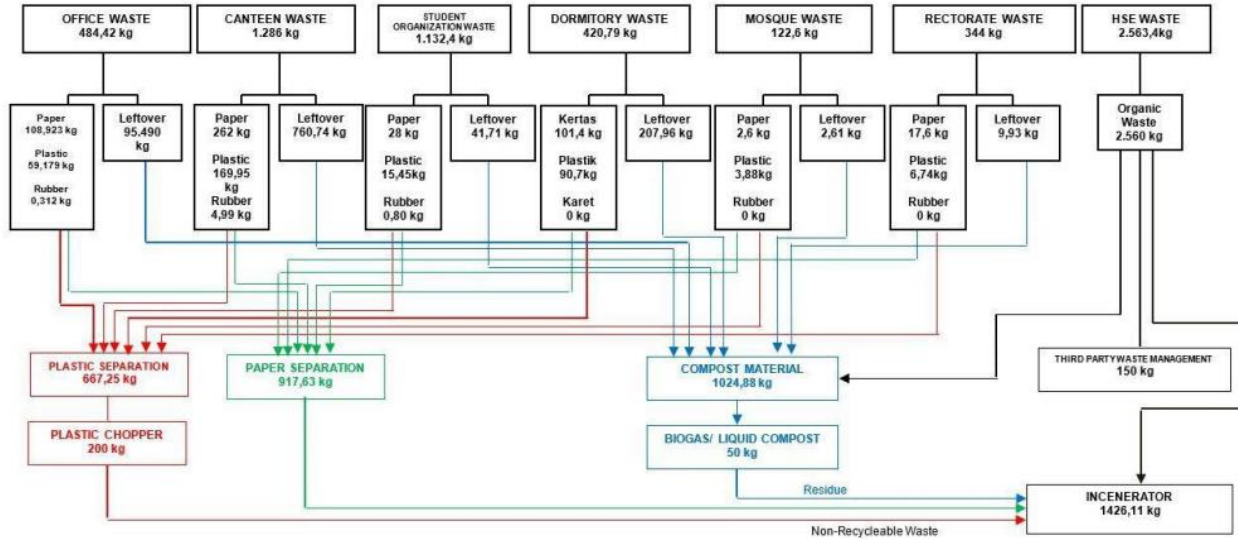

Total waste from several resources is 6353,61 kg (estimated 5-6 tons per day), a large portion of waste is recycled (77,55%) and only 22,44% is incinerated. Waste is recycled to various products such as brick, roof tile, compost, etc.